

Technical data sheet

PSI AUDIO

A225-M

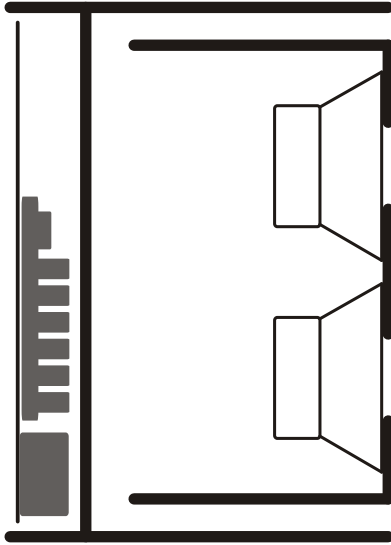

STEREO SYSTEM

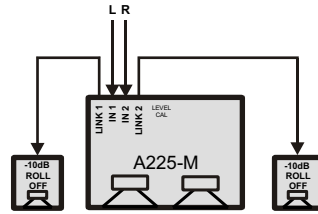

5.1 SYSTEM

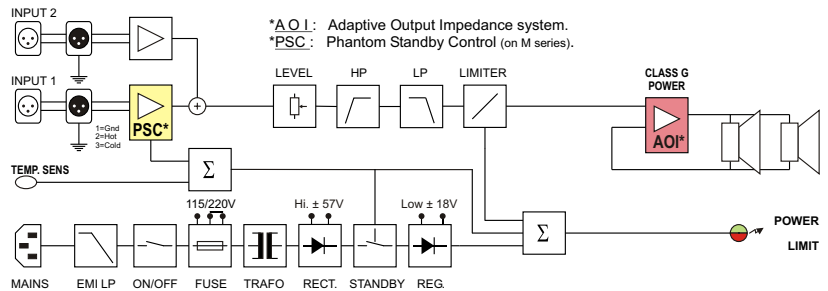
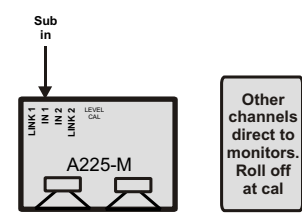

- Puissance RMS Power RMS **200 W**
- Puissance programme Program power **300 W**
- Impédance d'entrée Input Impedance **Sym, 10k Ohms**
- Sensibilité pour 100 dB @ 1m Sensivity for 100 dB @ 1m **0.775 V**
- Rapport signal sur Bruit Signal to Noise Ratio **-116 dBA**
- Saturation d'entrée Input Overload **24 Vpp**
- Niveau max. continu, 1m Continuous Max SPL, 1m **111 dB (single)**
- Niveau max. programme, 1m Program Max SPL, 1m **116dB / half space**
- Réponse à -6 dB Response at -6dB **24 - 100 Hz**
- Tolérances Tolerances **±2 dB (28Hz - 65Hz)**
- Distorsions THD Distortion THD **< 1.5% (50Hz-200Hz)**
- Système System **1 Way(s)**
- Fréquence de coupure Crossover frequency **90Hz**
- Dim. basses Ext. / Membrane Woofer's dim. Ext. / Diaphragm **2 x Ø 258 / Ø 210 mm**
- Connecteurs Connectors **2 x XLR F / 2 x XLR M**
- Signal entrée Signal input **1=GND, 2=(+), 3=(-)**
- Matériaux du boîtier Box Material **MDF / double box**
- Dimensions boîtier L x H x P mm Dimensions cabinet W x H x D mm **320 x 700 x 500**
- Poids brut / net Gross / Net Weight **43.1 / 38.4 Kg**
- Tension de secteur Voltage **115/230V (50-60Hz)**
- Consommation Consumption Standby-Quiescent-Max **1.7 - 4 - 200 W**
- Humidité Moy / Max Mean / Max Humidity **< 75% / < 90%**
- Température externe External Temperature **5 - 40 °C**

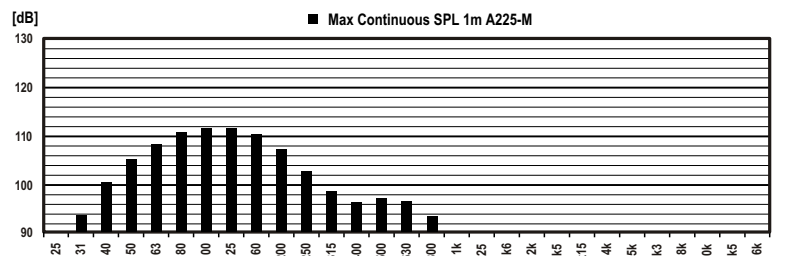
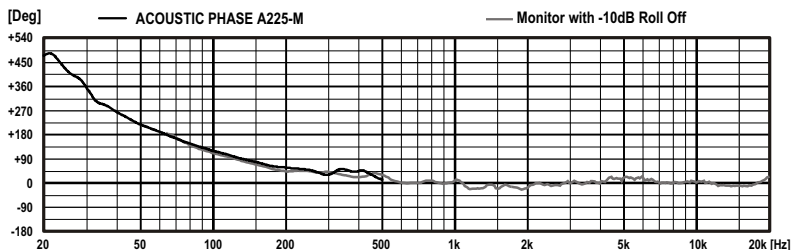
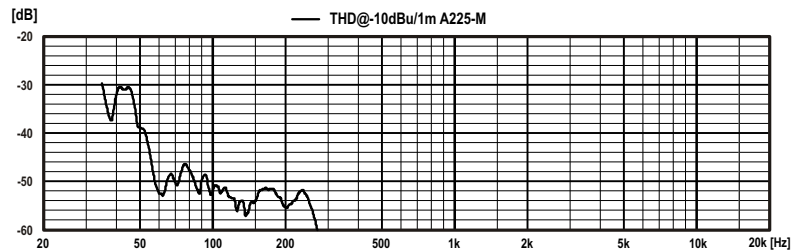
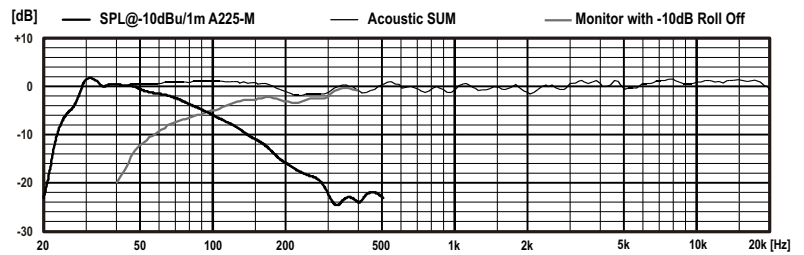

Mounting

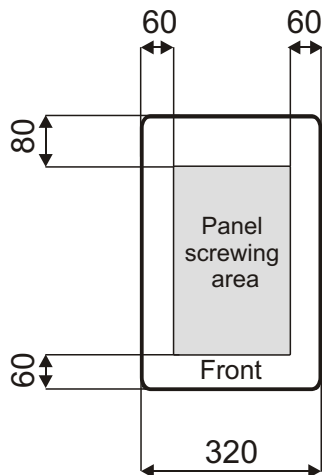

Bottom view

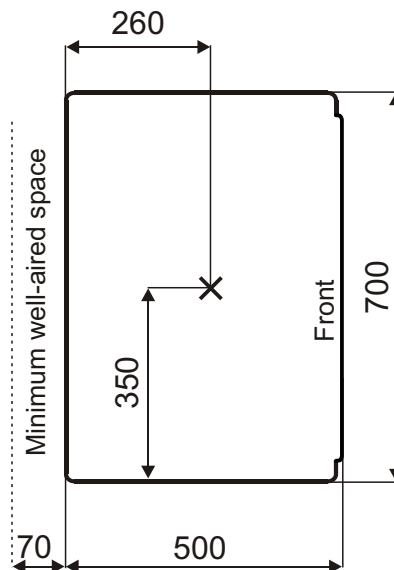

Side view

Acoustical axis

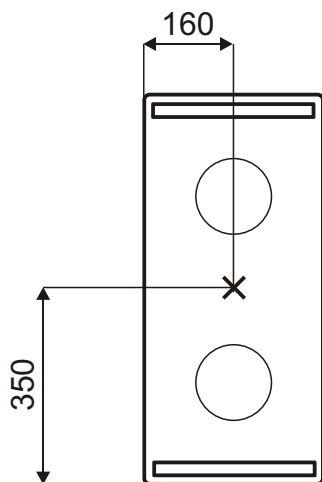

Front view

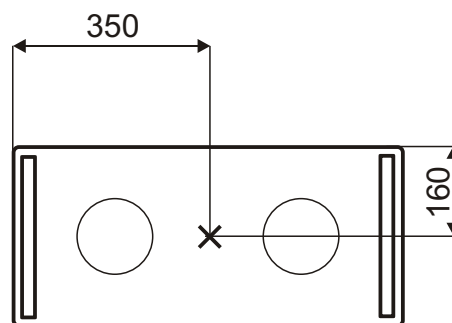

Measurement environment: Large anechoical room
 Temperature $23 \pm 2^\circ\text{C}$
 Humidity $50 \pm 20\%$